

PAC-MAN CHOMP MANIA™



Setup and Operations Manual

namco®



Safety

OPERATION

Before operating game, read this manual. Failure to properly install and operate this game could result in malfunction or accident. Operate the game in accordance with the manual.

TRANSPORTING

The cabinet is very heavy. Because the monitor is high, the cabinet is also very top-heavy. Use appropriate care when moving or transporting cabinet. It contains fragile glass and electronic components. Avoid rough handling.

HANDLING COMPONENTS

Many components are extremely sensitive to handling, environmental and Electrostatic Discharge (ESD) events—especially the computer. Do not handle it roughly. Before servicing, call your distributor and inquire about the PC warranty. Use proper ESD procedures when servicing. Protect components from harmful environmental conditions, such as extreme temperatures, excessive moisture or other damaging effects.

DISCONNECT POWER

Always turn the power off and unplug the unit before servicing or making adjustments unless otherwise instructed. Installing or repairing components while power is on can damage the components and void the warranty.

GROUNDING

Avoid electrical shock. Do not plug in AC power until you have inspected and properly grounded the unit. Only plug into a grounded, three-wire outlet. Do not use a “cheater” plug or cut off the ground pin on the line cord.

ELECTRICAL SHOCKS

There is no isolation transformer in the cabinet. Disconnect AC power before servicing. However, be aware that lethal voltages can remain in the electronic components even when AC power is disconnected. Use extreme caution when servicing. Verify that there is a working ground connection. If the unit sustains water damage, cease using it immediately and unplug AC power.

MONITOR

The monitor contains no user serviceable parts. Do not attempt to service the monitor.

POWER SELECTOR

Before installing game, ensure the voltage on the PC is set properly. There is a 115/230 VAC selector switch that must be set for the correct voltage for your site. Verify the fluorescent lamp rating. The rating must match the line voltage at the installation site.

POWER CORD

If the power cord is damaged or lost, replace it with an identical cord as supplied by the manufacturer or an authorized service agent.

SURGE SUPPRESSOR

It is recommended that you plug your game’s power cord into a surge suppressor to help protect from power surges that may damage sensitive electronic components.

PAC-MAN CHOMP MANIA™

WATER AND OTHER LIQUID SOURCE

Do not install game near sprinkler or other water jet sources. Do not use water jet to clean game. Keep minimum clearance behind game and wall for proper ventilation but also prevent access of liquid from spills and sprays from entering ventilation holes.

CONNECTORS

When servicing machine, ensure all connectors mate properly. If connectors do not slip in easily, do not force them. Connectors are often keyed and only connect one way. Check for correct orientation.

COMPUTER

The computer contains sensitive components, including a hard drive. Do not handle it roughly. Call your distributor before servicing its internal components. Ask about warranty information as it relates to the PC.

Do not turn the PC power switch on or off. It should remain permanently in the ON position.

Cycle AC power on or off with the cabinet power switch.

A dongle has been inserted into one of the USB ports. This is required for game play.

Do not remove the dongle except for troubleshooting purposes.

FLUORESCENT TUBES

A dropped fluorescent tube may break and implode. Shattered glass from the implosion can travel long distances and cause bodily injury. Use proper procedures when handling broken materials, as these items can contain hazardous material such as mercury or lead.

HAZARD TO EPILEPTICS

A small portion of the population has an epileptic condition that may cause seizures. Affected persons experience seizure while watching some television pictures or playing certain video games. People who have not had seizures may still have an undetected epileptic condition. If anyone in your family has experienced epilepsy symptoms (seizures or loss of awareness), consult your physical before using video games. While children play video games, a parent should observe. Be alert to the following symptoms: dizziness, altered vision, eye or muscle twitching, involuntary movements, loss of awareness, disorientation or convulsions. If you or your child experiences these symptoms, discontinue use immediately and consult your physician.

MANUAL

Keep this manual available and ready for use. If the game fails to function properly, turn off the machine and unplug the AC line cord. Contact your local distributor. Your warranty, when applicable, lasts 60 days from your purchase date. You may not reproduce this document or any of its contents without written authorization from Raw Thrills, Inc. or Play Mechanix™ Inc.

SPECIFICATIONS

For reasons such as performance, this product's specifications may change without notice. Federal patent, copyright and other intellectual property laws protect the content, devices and design of the game and its equipment.

Product Specifications

Electrical Power

United States, international and Japan

Inrush AC Current: 7 Amps

Operating AC Current: 5/2.5 Amps

Voltage: 115/230 VAC 50/60Hz

Dimensions

Height: 98" (2.48 meters)

Width: 30" (.76 meters)

Depth: 32" (.81 meters)

Temperature

50° F to 104° F

(10° C to 40° C)

Humidity

Must not exceed 95% relative humidity

PAC-MAN CHOMP MANIA™

Setup

Unpack Materials

1. Place the shipping crates on a flat, stable surface.
2. Cut the banding straps and remove the cardboard lids.
3. Lift off the large cardboard containers surrounding the front pedestal and monitor assemblies and remove any shipping cleats.
4. Remove the coin door key from the coin return slot.
5. Open the top coin door.
6. Locate the keys for the back door and the cash box door.
7. Open the cash box door and remove the cash box.
8. Check for shipping damage to the following:
 - Marquee and monitor
 - Cabinet decals
9. Check the AC line cord for visible signs of damage.

Pay particular attention to the plug and line cord insulation.

Check Electrical Settings

1. Verify the voltage in the nearest AC outlet.
2. Verify the AC outlet ground connection is present and working.
3. Open the back door of the monitor assembly.
4. Near the AC power transformer, verify the voltage selector switch is set to correct AC voltage.
5. Route the line cord so that the plug is near the AC outlet.
6. Replace the back door of the monitor assembly.

Startup Game

1. Plug in line cord to AC outlet.
2. Turn the power switch to ON.
3. Check that no component is excessively hot or emitting foul odors.

If not, turn off AC power and disconnect line cord. Refer to the diagnostic section of this manual.

Diagnostics and Adjustments

The Service Button Panel has four buttons, three of which can navigate the menu system.

But it is easiest to navigate with a Start button and trigger/grenade.

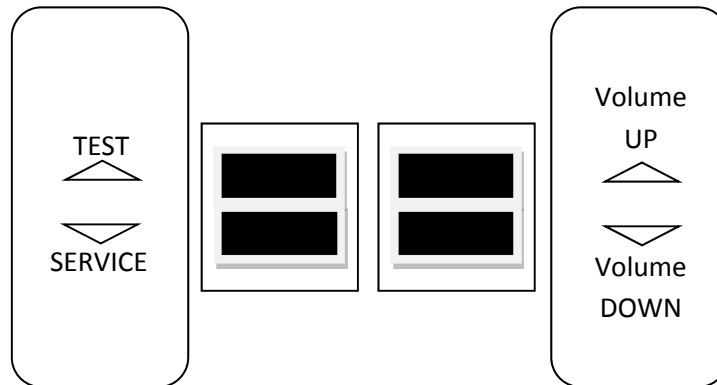

- Service Panel TEST/BACK button enters diagnostic system.
- Either Start button or SELECT button selects the highlighted option.
- Service Panel VOL DOWN button or moves down through menu or setting choices.
- Service Panel VOL UP button or moves up through menu or setting choices.
- Highlight and select Exit to return to previous screen.

An on-screen message acknowledges changes or when you exit a selection without making a change.

At the bottom of each screen there is a brief description of the menu option's function. A complete description is available here for all menu functions.

Instructions for completing your first calibration start on the next page.

PAC-MAN CHOMP MANIA™

Basic Functional Test On Initial Power Up

See the Diagnostic Section for further information.

1. Enter the Switch Test menu and verify all switches function.
2. Enter the Screen Test menu and verify that video is acceptable.
3. Enter the Sound Test menu and verify the audio works and is not distorted.
4. Enter the Coin Meter Test menu and verify the operation of the coin meter.
5. Enter the Cabinet Lamps Test menu and verify that all cabinet lights work correctly.
6. Enter the Watchdog Test menu, which reboots the game.
7. Upon a successful reboot, you are ready to make adjustments to pricing, volume and other functions found in the Adjustments, Audits and Diagnostics section.

Adjustments, Audits and Diagnostics

Main Menu

MAIN MENU

DIAGNOSTICS
COIN ADJUSTMENTS
PAYOUT ADJUSTMENTS
AUDITS
COPY AUDITS TO USB
VOLUME
ATTRACT VOLUME
ATTRACT MUSIC MODE
TICKET TERMINOLOGY
EXIT

Main Menu

Diagnostics Menu

This menu allows all game functions to be verified or diagnosed.

DIAGNOSTICS MENU

SWITCH TEST
MONITOR TEST
SOUND TEST
COIN / TICKET METER TEST
TICKET DISPENSER TEST
WATCHDOG TEST

EXIT

You can improve collections by periodically verifying proper game function and operation.

PAC-MAN CHOMP MANIA™

Main Menu

Coin Adjustments Menu

This allows customization of coin values, currency denominations, bill pulse and swipe credits.

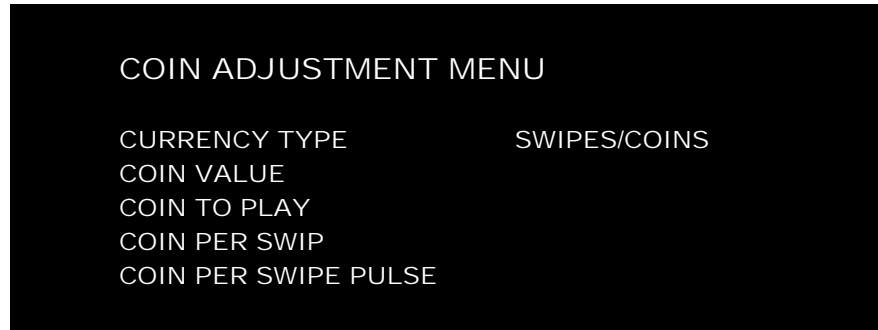

Main Menu

Payout Adjustments Menu

This menu allows for customization of target payout percentage, ticket value. Changes will result in audits being reset.



Software with Card Dispenser support is available for download. Contact Raw Thrills with any questions.

After downloading and installing software:

- 1. Enter the test menu and go to the Payout Adjustments Menu**
- 2. Select the Card Dispenser option and turn it on**
- 3. Select the Card Value option and select the value of the gift cards that will be used**
- 4. Select the Payout Percent option and set it to the desired payout**

If you want to display custom images:

- 5. Select the Load Custom Card Images option and follow the instructions in that menu**
- 6. Once the image(s) are successfully loaded, set the Card Display option to custom.**

Main Menu

Audits Menu

Audit screens help assess game performance, find intermittent problems, decide whether to adjust game difficulty and free game award and help maximize game earnings.

AUDITS

SYSTEM AUDITS
COIN AUDITS
PAYOUT AUDITS
GAME AUDITS

EXIT

Main Menu

Resets

RESETS MENU

CLEAR COINS
CLEAR TICKETS
RESET AUDITS
RESET ADJUSTMENTS
FACTORY RESTORE
CRC CHECK

EXIT

Maintenance

Hard Drive Recovery

Symptoms requiring hard drive recovery include

- File Test reports bad or missing files.
- Game fails to finish loading during startup.
- After resetting the AC power, an error is reported.
- You are prompted to insert a boot DVD.
- Erratic Game or Attract Mode.
- The following screen:



To identify corrupt files, press Test, choose System Test Menu and run the File Test.

The only way to repair corrupt files is to recover the hard drive, as detailed below.

COMPUTER

The computer contains sensitive components, including a hard drive. Do not handle roughly. Call your distributor before servicing its internal components. Ask about warranty information as it relates to the PC.

Do **not** use the PC on/off switch. Turn AC power on or off with the cabinet power switch.

1. With game and PC on, verify that the RIO board has power. If not, see Troubleshooting.
2. Open the Coin door.
3. Open the PC DVD-ROM tray by reaching back to the PC and pressing the Open/Close button on the drive bay.
4. Insert the first of two restore DVDs (labeled *Disc 1*) into the tray.
5. Close the tray by pressing the Open/Close button again.
6. Turn cabinet power switch to OFF. Wait 30 seconds.

PAC-MAN CHOMP MANIA™

7. Turn cabinet power switch to ON.
8. Recovery begins automatically when PC boots up.
9. If recovery does not begin, check to ensure disc is inserted correctly and is not damaged.
10. Initial software loading may take several minutes. Check progress periodically.
Do not interrupt power or reset the game during recovery.
11. At some point, the game will eject *Disc 1* and prompt you to insert *Disc 2*.
Swap discs and close the tray.
12. When software has been loaded, a message indicates that restore is complete. When instructed to remove *Disc 2*, open DVD-ROM drive tray and remove *Disc 2*.
13. Turn cabinet power switch off.
14. After 30 seconds, turn cabinet power switch on.
15. Game will reboot and enter calibration mode.

BIOS Settings/Power Management

NOTICE

The PC ships with correct BIOS settings. Making changes to the BIOS different from the description below may adversely affect game functions.

This BIOS setting lets the PC automatically power up. With the setting enabled, the PC reboots when it detects AC power. This eliminates the need to manually turn the PC back on after power disruption.

Do **not** use the PC on/off switch. Turn AC power on or off with the cabinet power switch.

1. Turn cabinet power switch off.
2. Open rear of cabinet.
3. Connect a USB keyboard to the PC.
4. While holding the Delete key on the keyboard down, turn cabinet power switch on.
5. When the BIOS menu screen appears, make the following adjustments.

Feature	Set to
Standard CMOS Features > Drive A.....	[none]
Standard CMOS Features > HALT ON.....	[No Errors]
Advanced BIOS Features > Boot Sequence.....	1 st CD-ROM 2 nd Hard Disk
Advanced BIOS Features > APIC Mode	Disabled
Advanced Chipset Features > Frame Buffer	[16M]
Advanced Chipset Features > PMU > CPU Frequency	[200.0]
Power Management Setup > PWRON After PWR-Fail.....	[On]

6. Follow instructions on screen to save and exit.
7. PC will reset and load the game.

PAC-MAN CHOMP MANIA

ELECTRICAL DIAGRAM

AND

MECHANICAL ILLUSTRATIONS

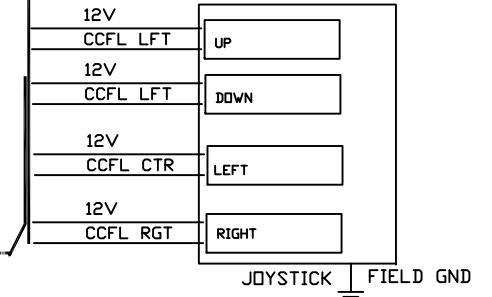
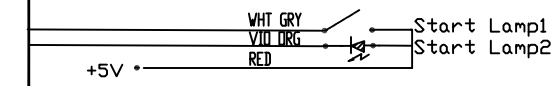
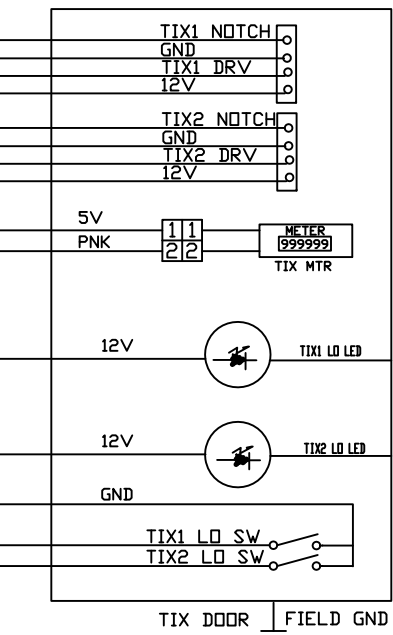
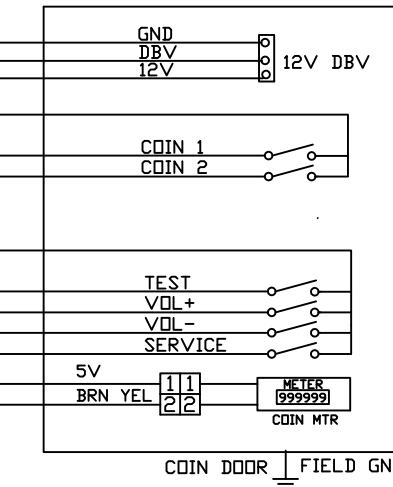
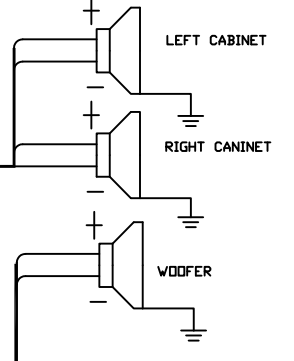
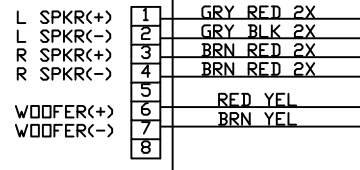
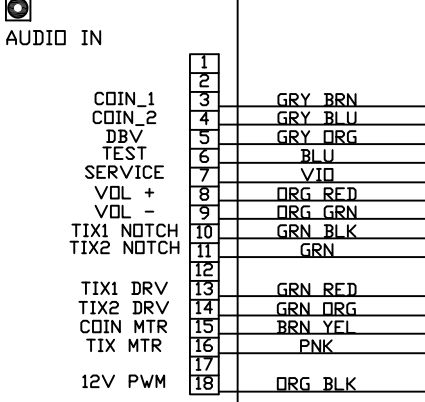
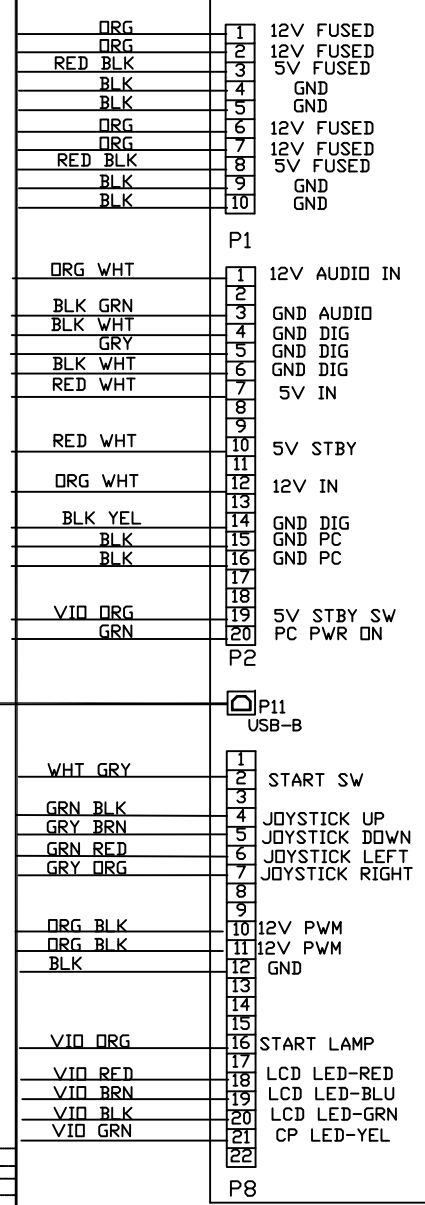
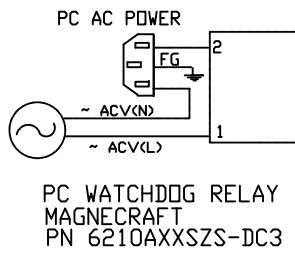
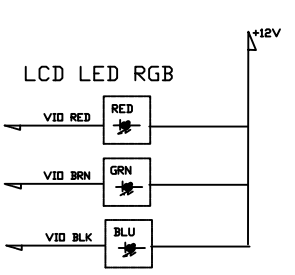
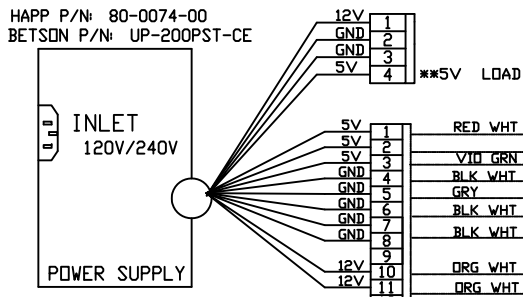
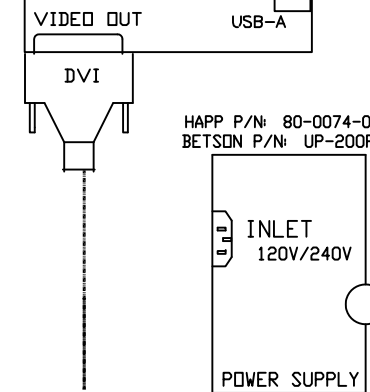
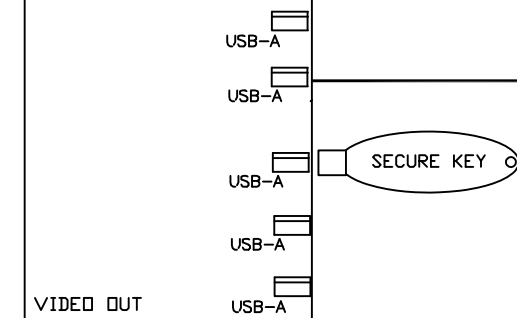
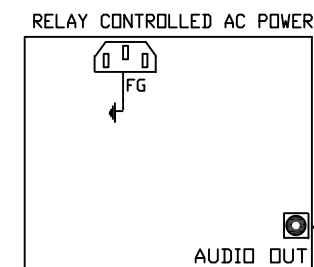
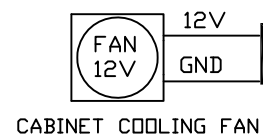

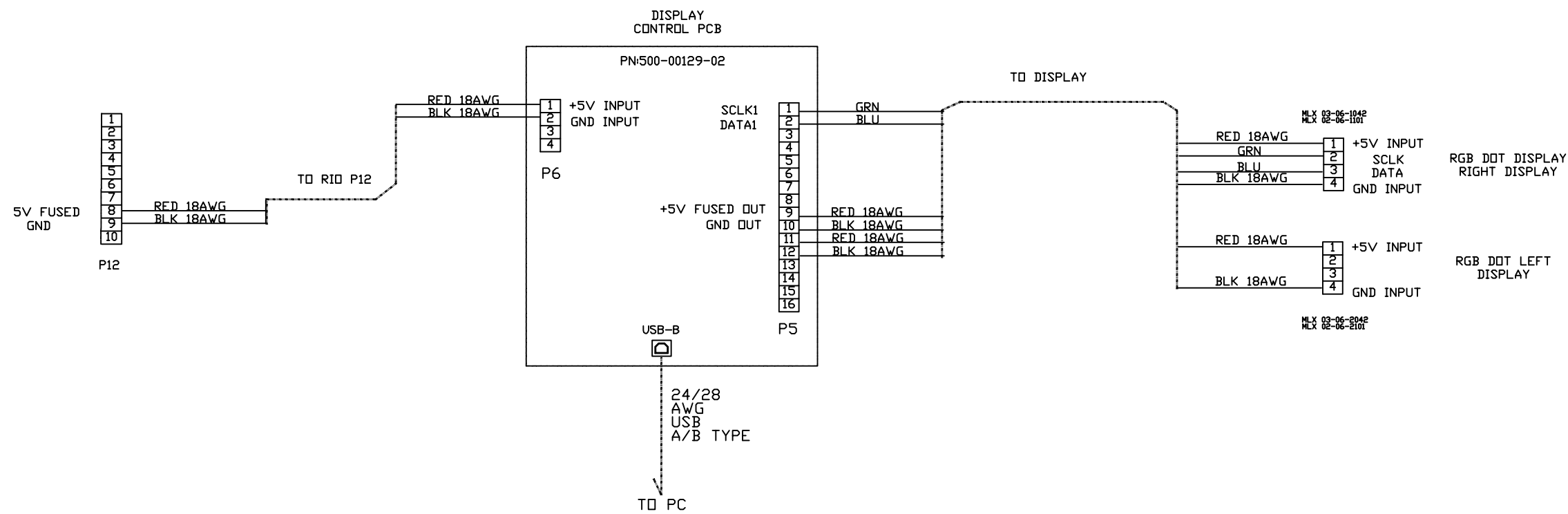

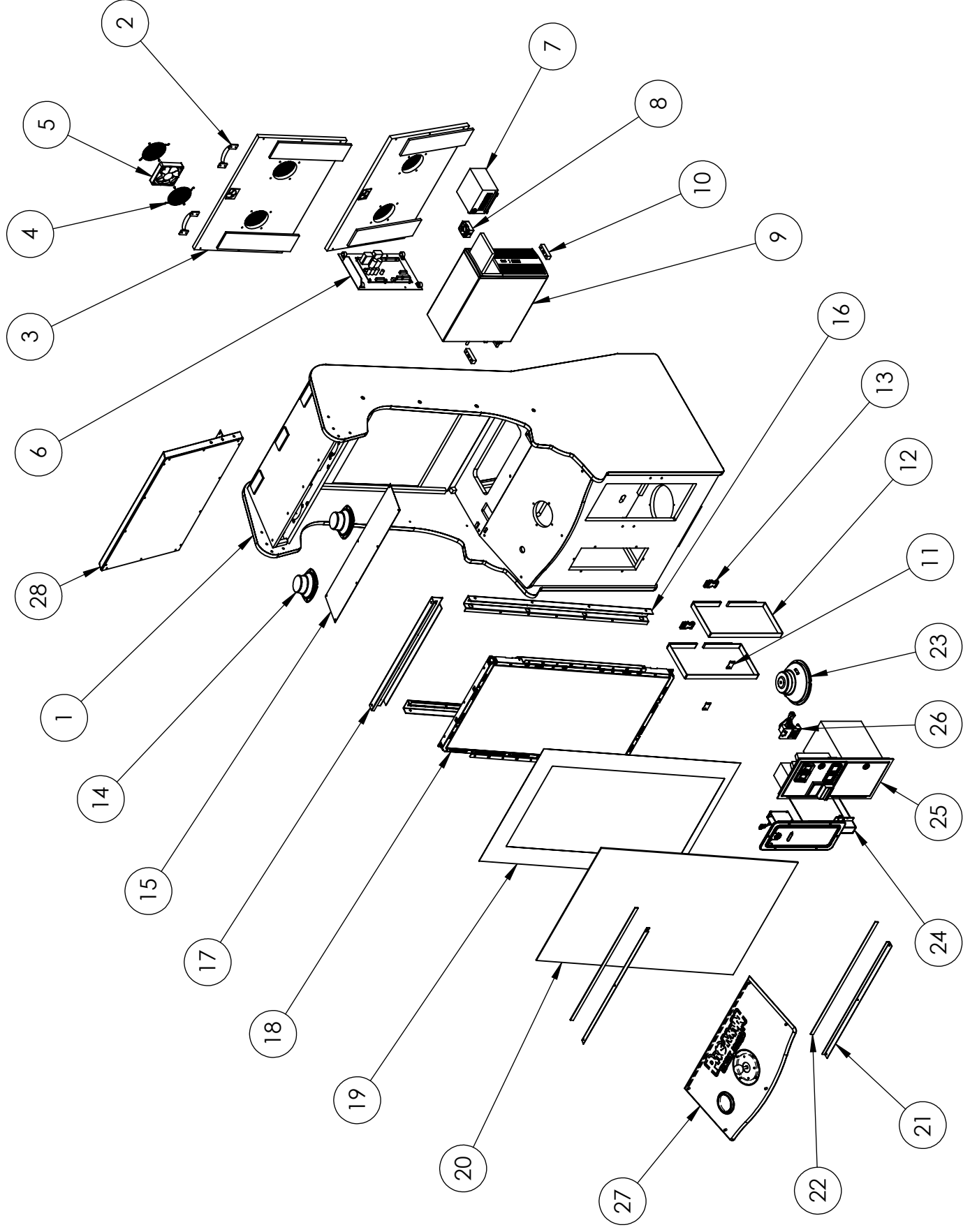

Pacman - 42" LCD
(BOM on next page)

Pacman - 42" LCD: BOM

ITEM NO.	PART NUMBER	DESCRIPTION	QTY.
1	601-00630-01	Pacman 42" LCD Cabinet	1
2	600-01110-01	McMaster-Carr: Black Handle (1646A16)	2
3	601-00634-01	Pacman - Lower Back Door (Assembled)	2
4	800-00001-00	120mm Wire Fan Guard	2
5	820-00012-00	Cooling Fan(standard size): 12VDC, 3W, 80CFM	1
6	RIO-Hardware Assy	RIO Assembly (with Mounting Plate)	1
7	2-1-02-00-00-017	APS Power Supply (Bracket #90-AP188)	1
8	800-00040-01	Magnecraft - Solid State Relay - 6210AXXSZS-DC3 (6210DSX-1)	1
9	HP6005	(or approved equivalent PC)	1
10	601-00580-01	PC Wood Cleat	2
11	600-00891-01	Securing Nylon Strap Plate	2
12	87425K76 (56 length)	McMaster-Carr: Nylon Strap 0.075" Thick, 1" Width, Black (56" Length)	2
13	29705T86	McMaster-Carr: Plastic Buckle for Webbing NO Sew Squeeze-Release for 1" Wide Webbing	2
14	2-1-10-00-00-000	Goldwood: 5.25", 8 Ohm Full Range Speaker	2
15	600-01103-01	Pacman - Perforated Speaker Grill Cover	1
16	Monitor_Mounting_Bracket_& Light_Assy	Pacman - Monitor Mounting Bracket Assembly	2
17	Above_Monitor_Light_Bracket_Assy	Pacman - Above Monitor Light Assembly	1
18	809-00004-01	42" LCD Assembly	1
19	606-00814-01	Pacman - Monitor Frame Translite	1
20	600-01048-01	Pacman - Monitor Glass	1
21	600-01053-01	Pacman - Monitor Glass Retainer (2)	2
22	Foam_Tape_.125Tx.625wx28.4375L	Single Sided Foam Tape (1/8" Thick, 5/8" Wide, 28 7/16" Long)	2
23	2-1-18-00-00-000	Goldwood: 8" Woofer, 4 Ohm, Poly-Mica Cone	1
24	800-00043-01	Happ: Ticket Dispenser Door Assembly	1
25	800-00005-01	Happ: Mid-Width Coin Door Assembly	1
26	810-00053-01	Test Service Button Assy	1
27	PacPot_CP_Assy	Pacman - Control Panel Assembly	1
28	Pacman_Marquee_Assy	Pacman - Marquee Assembly	1

ITEM NO.	PART NUMBER	DESCRIPTION	QTY.
1	608-00164-01	Pacman - Hinged Marquee Box	1
2	603-00580-01	2" Diameter PVC Grommet	1
3	500-00093-01 (65CM)	White Flexible LED Tape (65CM - 39 LEDs)	2
4	500-00132-01	LED Display Matrix PCB	2
5	606-00815-01	Pacman - Marquee Translite	1
6	600-01049-01	Pacman - Marquee PETG	1
7	500-00129-02	LED Controller PCB	1

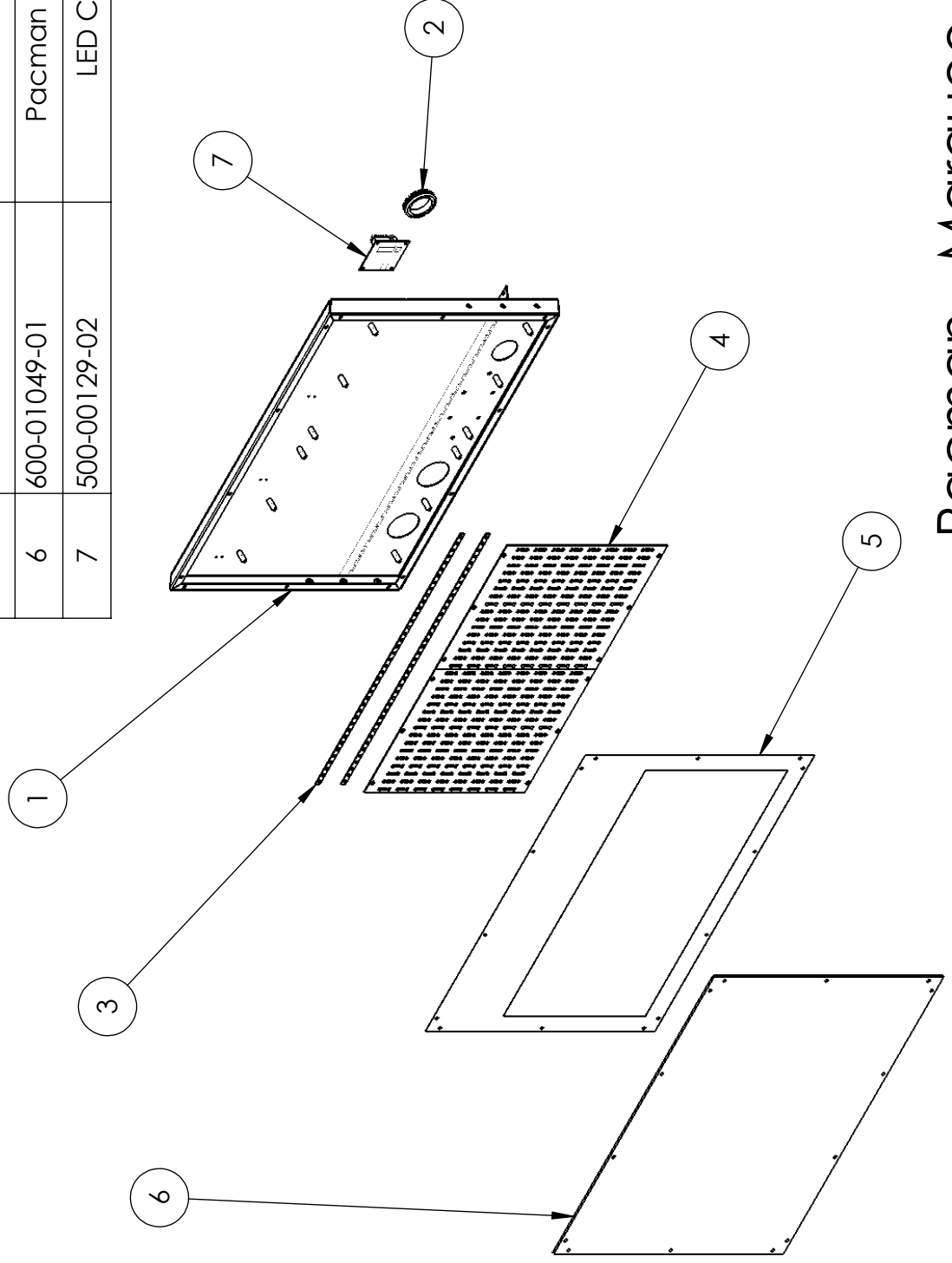

Pacman - Marquee Assembly

ITEM NO.	PART NUMBER	DESCRIPTION	QTY.
1	603-00633-01	Pacman - CP Edge Glow	1
2	RGB Strip (65CM)	RGB Flexible LED Tape (65CM - 39 LEDs)	1
3	702-00052-00	Happ: Jumbo Round With Locking Lampholder (6VDC Red LED), .187 Gold MS	1
4	Mounted_Joystick_Assy	Pacman - Joystick Assembly	1

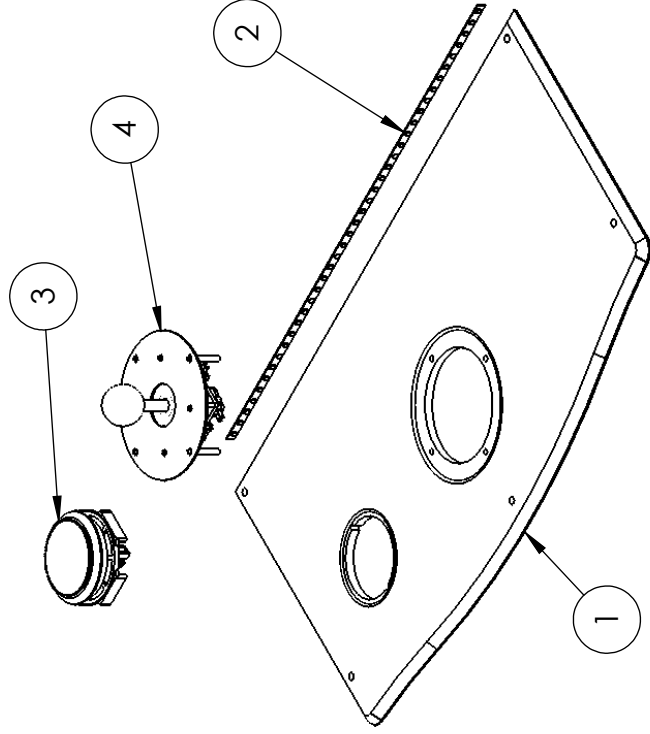

Pacman - Control Panel Assembly

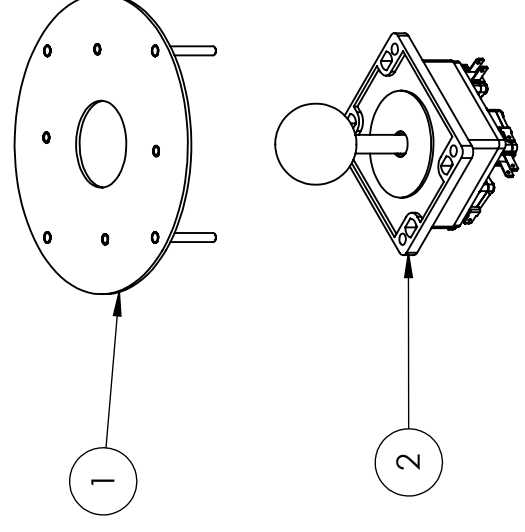

ITEM NO.	PART NUMBER	DESCRIPTION	QTY.
1	600-01061-01	Pacman - Joystick Mounting Plate	1
2	800-00042-01	Happ: Super Joystick 4 Way W/ 43MM Yellow Bubbly Ball	1



Pacman - Joystick Assembly

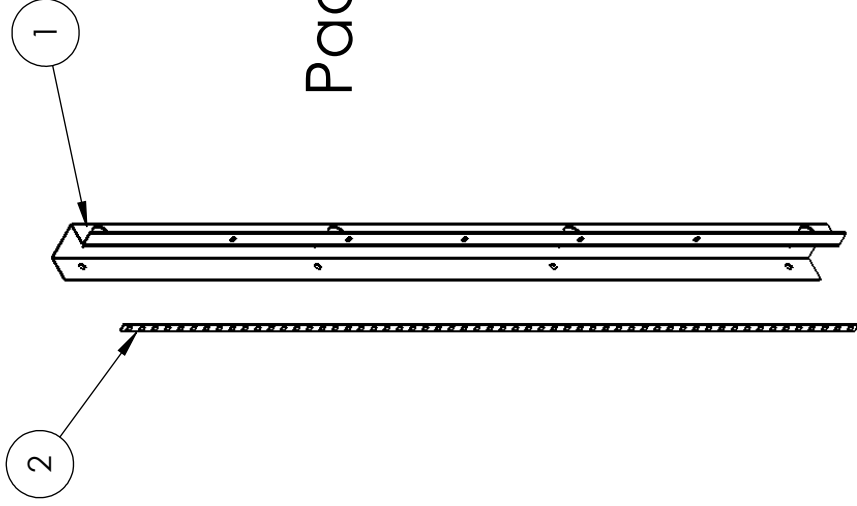

Pacman - Monitor Mounting Bracket Assembly

ITEM NO.	PART NUMBER	DESCRIPTION	QTY.
1	600-01055-01	Pacman - Monitor Mounting Bracket	1
2	RGB Strip (95CM)	RGB Flexible LED Tape (95CM - 57 LEDs)	1

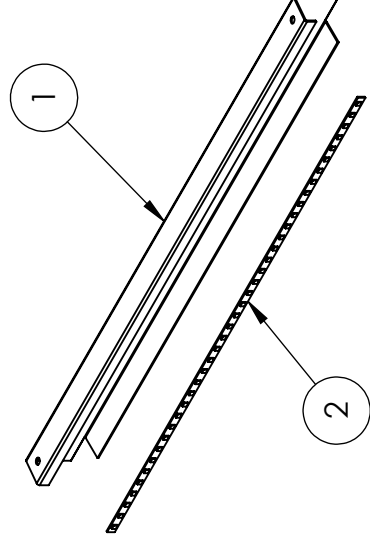

ITEM NO.	PART NUMBER	DESCRIPTION	QTY.
1	600-01056-01	Pacman - Above Monitor Light Bracket	1
2	RGB Strip (65CM)	RGB Flexible LED Tape (65CM - 39 LEDs)	1



Pacman - Above Monitor Light Assembly

ITEM NO.	PART NUMBER	DESCRIPTION	QTY.
1	600-00513-01	RIO-Mounting plate Chassis	1
2	500-00040-01	RIO-board	1

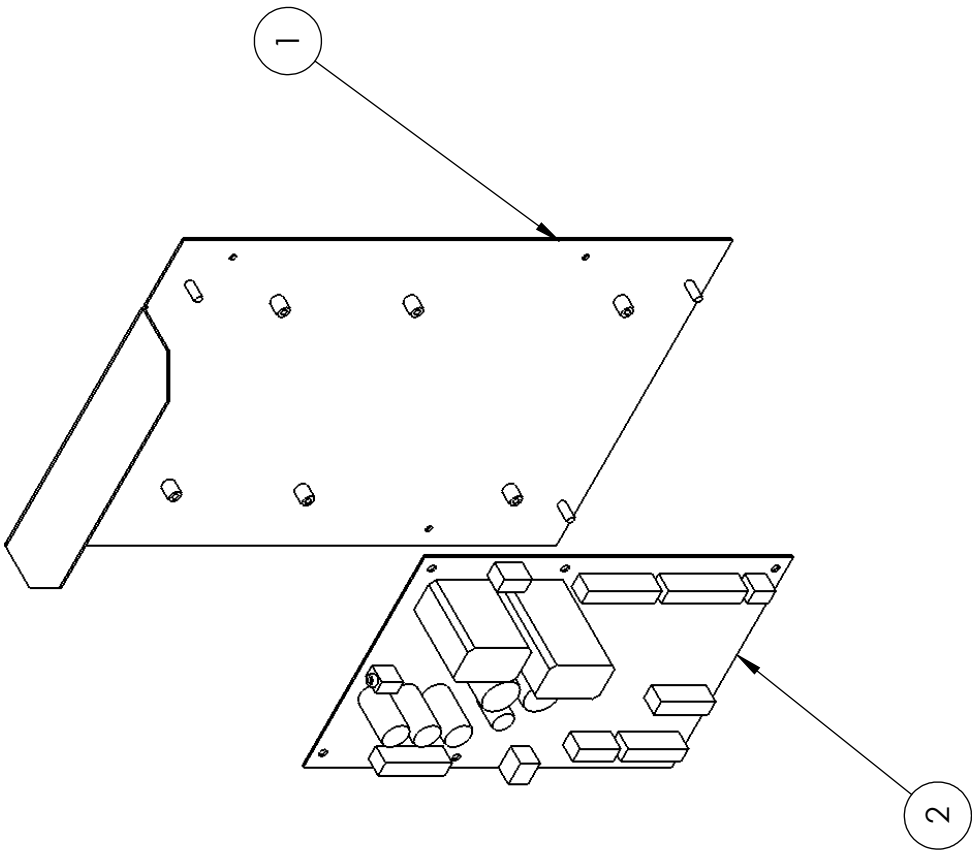

RIO Assembly (with Mounting Plate)



PAC-MAN CHOMP MANIA™

NOTES: